



INTREPID INDUSTRIES INC.

2305 S. Battleground Road
La Porte, TX 77571-9475

T: 281.479.8301
F: 281.479.3453

sales@intrepidindustries.com
www.intrepidindustries.com

UNIVERSAL DOUBLE BAR SAFETY GATE (UDG)



EASY INSTALLATION

- Universal hinge design provides either left-hand or right-hand swing
- Universal hinge design will attach to most common guardrails
- For angle iron, flat bar, or plate installation: 2 bolts for hinge and 1 bolt for block
- For pipe or square tube: Add-on installation kits are available

DESIGN

- Gate automatically closes due to gravity
- Rises when opened; returns closed when released
- Design does not depend on springs, cams, bearings, or the operator
- Has a horizontal swing, not a vertical drop
- Available in 4 standard sizes
22" / 560mm 27" / 690mm
32" / 820mm 37" / 950mm

WIDESPREAD SUCCESS

- Proven design has been successfully used for over 30 years
- Sold more than 500,000 units in over 60 countries and all 50 US states
- Specified by many multi-national industrial companies
- Recommended by many engineering firms
- Exceeds US OSHA and other worldwide safety standards

MATERIAL STRENGTH & WEATHERABILITY

- Withstands 400 lb (180 kg) impact test at ambient, as well as extreme cold temperatures (-70°F / -56.7°C)
- Excellent outdoor weatherability; supports heavy loads 24/7
- In sunlight, material will surface discolor but not degrade
- QUV testing data shows no material property changes. Testing data available on website.

BENEFITS

- Safe & effective
- Maintenance free
- Long service life
- Proven design
- Provides the protection you want
- Economical

CONSTRUCTION

- All molded parts are made from a strong, rigid, UV-resistant polyurethane
- Molded parts colored throughout with safety yellow
- Fluoropolymer wear plate and bushings facilitate easy open & close
- Galvanized hardware provided



INTREPID INDUSTRIES INC.

2305 S. Battleground Road
La Porte, TX 77571-9475

T: 281.479.8301
F: 281.479.3453

sales@intrepidindustries.com
www.intrepidindustries.com

UDG SAFETY GATE DESIGN CONSIDERATIONS

--- ATTACHES EASILY TO ---

ANGLE IRON



FLAT BAR



WELDED PLATE



PIPE



SQUARE TUBE



INTREPID UDG-37 MAXIMUM SWING ROTATION, RISE, AND KICK-OUT

INTREPID UDG-37
Fully Open = 112 degrees

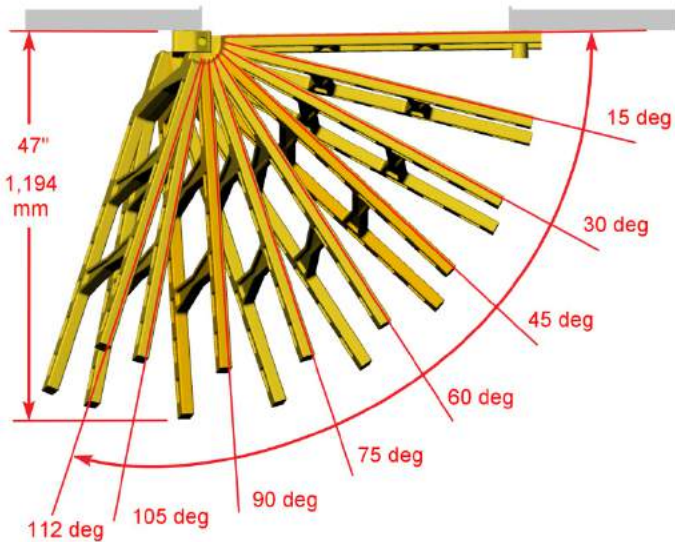

DESIGN CONSIDERATIONS WHEN GATE IS IN A TIGHT AREA

When the Safety Gate is to be mounted in a tight space, such as a corner or a narrow catwalk area, the designer must be aware of both the rise and the kick-out caused by the swing rotation of the self-closing gate. This is depicted in these two drawings.

INTREPID UDG-37
Maximum Rise = 14" / 356 mm

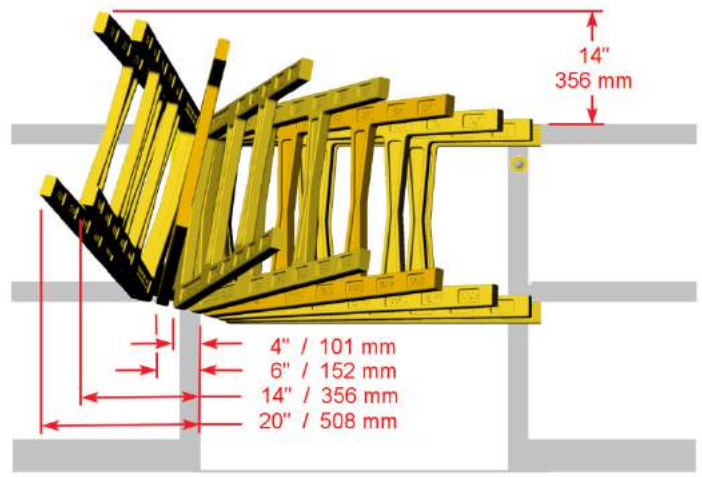

Please allow as much room as possible so that the gate can swing fully open. However if space is tight, then try to provide at least a 4" – 6" corner so that the gate can swing open as much as 75° – 90°.



INTREPID INDUSTRIES INC.

2305 S. Battleground Road
La Porte, TX 77571-9475

T: 281.479.8301
F: 281.479.3453

sales@intrepidindustries.com
www.intrepidindustries.com

UDG SAFETY GATE TYPICAL INSTALLATION

MOUNT HINGE

Mount hinge as close as possible to the top of guardrail. Ideally the top bolt hole should be located 1" down from top rail, but this may need to be adjusted depending upon the guardrail members. Typical measurements are shown in drawing below.

Position two 9/16" holes on 6 1/4" centers for two 1/2" carriage bolts (4" top and 5" bottom). Holes should be positioned to allow clearance for tightening 1/2" nuts.



MOUNT BLOCK

*****NOTE: BLOCK INSTALLATION NOT OPTIONAL*****

Mount the block so that it is positioned at least 1" BELOW the closed bar. Allow clearance for tightening the 1/2" nut.

Position one 9/16" hole for mounting the block with the 1/2" x 4" carriage bolt.

Block should not interfere with the opening or closing of the gate. It is intended to provide vertical support in an emergency. The block should be located at least 5" below where the top of the hinge is positioned.



REMEMBER — YOU MUST MAKE SURE:

- Safety Gate is no more than 42" above the platform surface to avoid too large of an opening below the gate
- Double bar gate is long enough to contact, and extend past, opposite side guardrail post by 1" or more
- The block is provided to resist vertical deflection. The block SHOULD NOT MAKE CONTACT WITH THE GATE OR INTERFERE WITH IT SWINGING CLOSED

TYPICAL INSTALLATION OF UDG-37 Universal Double Bar Safety Gate

RIGHT HAND SWING INSTALLATION on Angle Iron Guardrail
NOTE: Only one Hinge and one Block are required for the UDG Gate

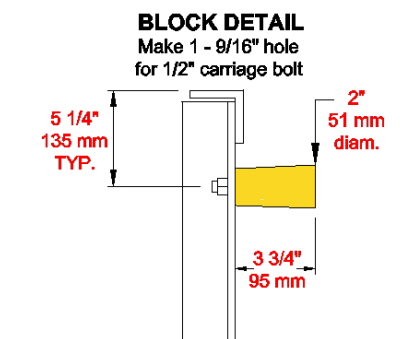
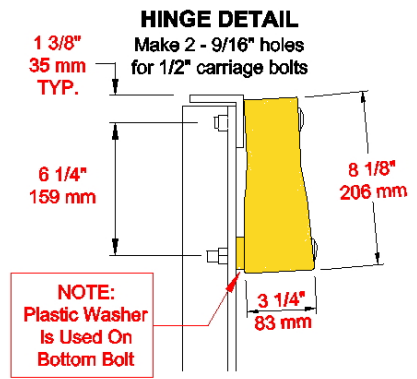
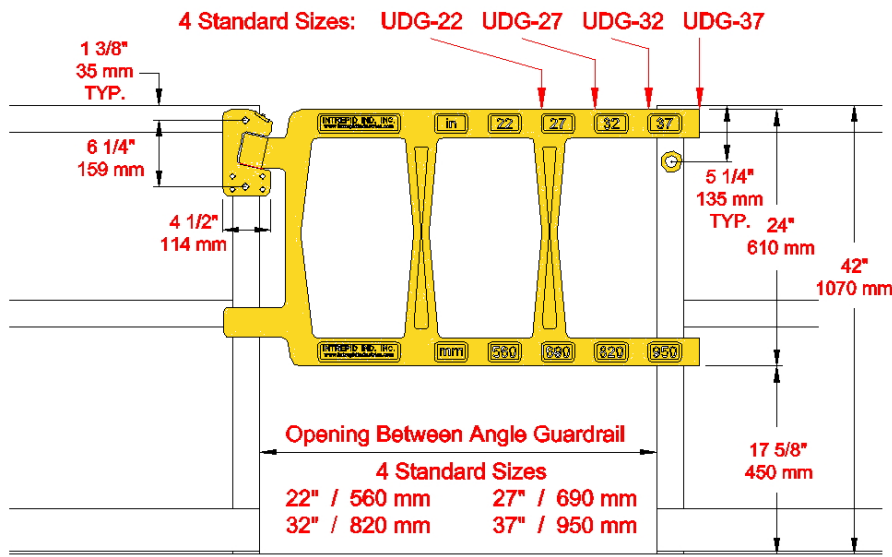



INTREPID INDUSTRIES INC.

2305 S. Battleground Road
La Porte, TX 77571-9475

T: 281.479.8301
F: 281.479.3453

sales@intrepidindustries.com
www.intrepidindustries.com

UDG SAFETY GATE ADD-ON INSTALLATION KITS



Pipe or Square Tube Guardrail Attachment

These add-on kits allow for easy installation onto both pipe and square tube guardrail. The pipe kit attaches to either 1 1/2" or 2" pipe. The square tube kit can attach to square tube as large as 2 1/2". Both are great alternatives to welding plate. Instructions below are for the pipe kit. Square tube instructions are very similar.



INSTALLATION INSTRUCTIONS

Locate the block in the box labeled "UDG Angle Iron Installation" (the remaining contents in the box will not be used.)

Attach block to the 4" x 2 3/8" metal plate in the pipe kit using 1/2" nut.



HINGE INSTALLATION

Position top of the 4" x 5" metal plate 5 3/4" below top of the guardrail (plate should be configured with the four holes at the top and the two slotted holes at the bottom).

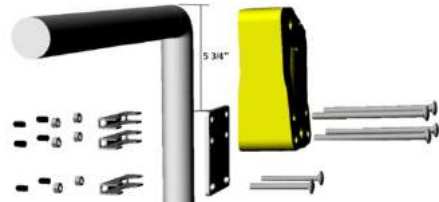

Attach plate by putting the two 3/8" x 3 1/2" carriage bolts through the plate.

Bolts will pass through clamp with the pipe guardrail positioned between the plate and the clamp. Securely fasten by tightening two 3/8" nuts.

Secure the hinge & gate to the plate using four 3/8" x 7" carriage bolts and the other 2 clamps.

Top of the hinge will be positioned close to the top of the guardrail.

Cover exposed threads of bolts with the black vinyl end caps supplied.

BLOCK INSTALLATION

Install the block and plate assembly onto the opposite guardrail post, using two 3/8" x 3 1/2" carriage bolts (the plate should be configured so that block is on top).

Loosely install two 3/8" nuts to the carriage bolts. Once the block is positioned approximately 1" below the bar of the gate, tighten the nuts. Cover exposed threads of bolts with the black vinyl end caps supplied.

NOTE: The bar of the gate should not rest on the block. Likewise, the block should not interfere with the opening or closing of the gate. It is intended to provide vertical support in an emergency.



HoldTight Magnet Closure

The add-on HoldTight Magnet Closure Kit provides a way to hold the Safety Gate securely in a closed position. All parts of the kit have been designed and tested for outdoor use and exposure. In fact, it has successfully held the Intrepid Safety Gate closed on an offshore rig along the Canadian-Atlantic coastline where the winds are around 30 knots with gusts of 70-80 knots!



INSTALLATION INSTRUCTIONS

Determine where the Safety Gate contacts the vertical guardrail post. Mark and drill a 1/4" hole through the top bar of Safety Gate. Since the bar has both recessed and solid areas along its length, use the shorter machine screw for the recessed areas and the longer machine screw for the solid sections.

Two nuts are used to secure the magnetic disk. In this way, the magnet can "float" or "wobble", and still make good, flat contact with the metal guardrail post.

Once the screw, nuts, and magnet are together, use the washer, (plus additional nuts, if required) and the cap nut to secure the unit to the gate.

